

Alpine

THE RENAISSANCE SERIES

Outdoor Fireplace Systems
O36/ O42 Model Series

Unique Blend of
Beauty,
Convenience &
Versatility



Stylish extras for homeowners...Better value for builders

FIREPLACES
FOR BUILDERS
Fmi

Classic Beauty - Ultimate Flexibility

THE RENAISSANCE SERIES

Alpine

Outdoor Fireplace Systems
O36/ O42 Model Series

America is moving outdoors. And Fmi's new Alpine outdoor vent-free gas fireplace systems transform just about any backyard into a private year 'round oasis. An Alpine offers the beauty and ambiance of a real wood outdoor fire but without the smoke, hassle and mess. They can be installed virtually anywhere, and come in one beautiful and complete package with all the conveniences and new features homeowners will love!

Homeowner Highlights:

- **Eye Dazzling Beauty**—The Alpine features clean, brushed stainless steel faces and stainless mesh spark screens. The screens tuck out of sight behind hidden side pockets to maximize the beauty of the fireplace. They also include the industry's finest colored and textured refractory brick liner for a true masonry look. Integrated gas log sets feature intricately detailed bark, split wood and charred textures. Random dancing yellow flames with a deep glowing ember bed complete the full and realistic flame picture.
- **Variety of Sizes & Features**—Available in 36" and 42" sizes with either natural white or warm red brick, there's a perfect Alpine for any outdoor room. All controls are hidden to eliminate hearth clutter and maximize the real woodburning feel. All models feature glowing ember bed burner with remote ready control and push button ignition.
- **Versatility & Economy**—An Alpine is an extremely economical installation since it requires no venting or chimney construction whatsoever. Not only does that reduce costs, but may also be allowed where restrictions prohibit typical vented outdoor fireplaces.

Builder Benefits:

- **Economical and Versatile**—When you eliminate all that venting and chase construction, installation costs come way down. And their versatile, compact design provides enough flexibility for small, unconventional or restricted lots.
- **Secure, straight installation**—We've included full-length, solid stainless steel nailing flanged drywall stops on the Alpine built into all 3 sides of the face frame.



O36NRRA includes "stacked" style, warm red textured brick.



O42PRA operates on propane gas and features textured brick refractory in natural white.

Alpine Product Offering Summary

- 36" and 42" Opening Widths
- Stacked or Herringbone Brick Pattern in Natural White or Warm Red
- Natural Gas or Propane Applications



Accessories include a matching fireplace opening cover to protect against weather and dirt, as well as unwelcome animals and pests.



Alpine log and burner systems feature intricately detailed log arrangements, random, dancing flames with glowing coals and embers.

Size	BTU(NG)	BTU(LP)
36"	49,000	41,000
42"	53,000	45,000

Accessory Offering

- Corrosion resistant water drainage pans
- Stainless steel fireplace opening cover
- Extruded Aluminum Perimeter Trim Kits (Black, Brass & Platinum)
- Remote Control Kits
- Decorative Ash Bed/ Control Cover Kit

Dimensions

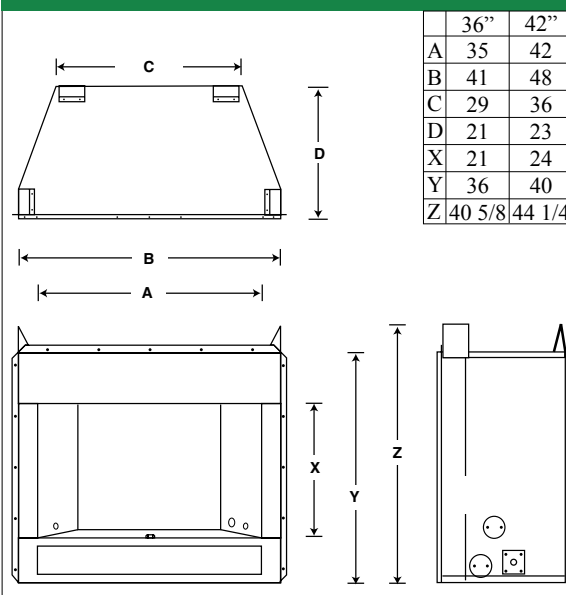

www.fmiproducts.com
For more information (866) 328-4537



Printed in U.S.A.